



: 013N1600
Unilift KP 350 A 1

1-

F,

,5

./

10

: 0 .. 50 °C
998.2 / ³

: 10

DIN W.-Nr. 1.4301
AISI 304

DIN W.-Nr. 1.4031
AISI 304

Rp 1 1/4
: 2

- P1: 700

: 50 Hz

: 1 x 220-240

: 3.2 A

- : 10 /400

(IEC 34-5): IP68

(IEC 85): F

: 5

: SCHUKO

7

7.5

0.013 ³

1 Unilift KP 350 A 1



: 013N1600

1-

F,

,5

10

: 0 .. 50 °C
 998.2 / 3

: 10

DIN W.-Nr. 1.4301
 AISI 304

DIN W.-Nr. 1.4031
 AISI 304

Rp 1 1/4
: 2

- P1: 700

: 50 Hz

: 1 x 220-240

: 3.2 A

- : 10 /400

(IEC 34-5): IP68

(IEC 85): F

: 5

: SCHUKO

7

7.5

0.013 ³

013N1600 Unilift KP 350 A 1 50

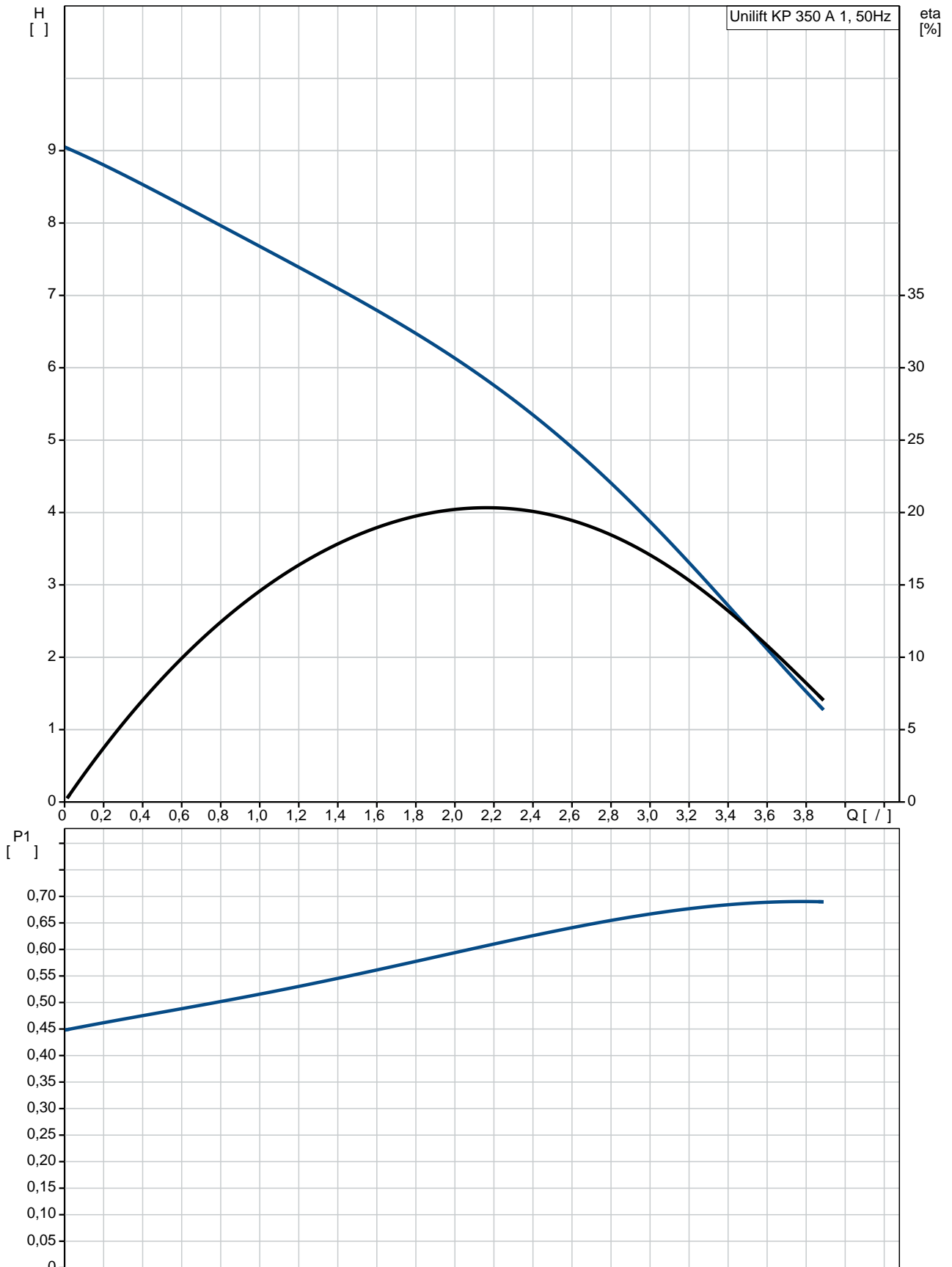

Unilift KP 350 A 1
 013N1600
 EAN : 5700393433137

Ma : 3.89 /
 : 9
 : 10
 : A

DIN W.-Nr. 1.4301
 AISI 304

DIN W.-Nr. 1.4031
 AISI 304

Rp 1 1/4
 : 2

: 0 .. 50 °C
 : 998.2 / ³

- P1: 700
 : 50 Hz
 : 1 x 220-240
 : 3.2 A
 - : 10 /400

(IEC 34-5): IP68
 (IEC 85): F

: CONTACT

: 5
 : SCHUKO

: 7
 : 7.5
 : 0.013 ³

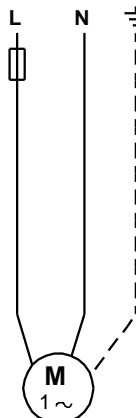
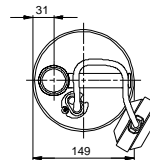
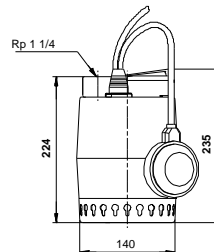
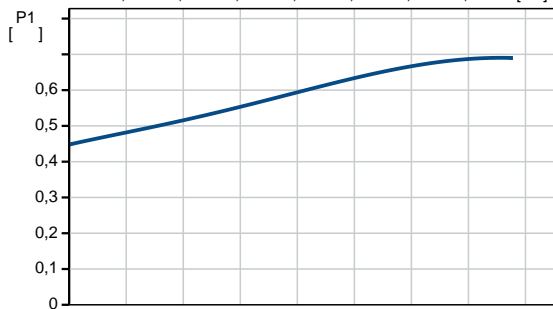
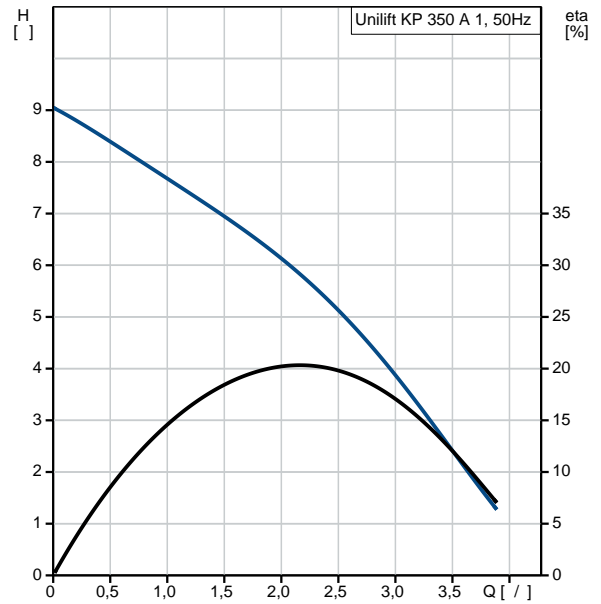

013N1600 Unilift KP 350 A 1 50

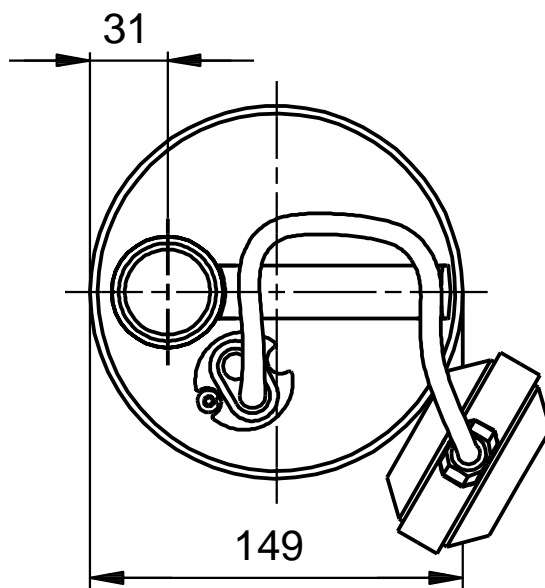
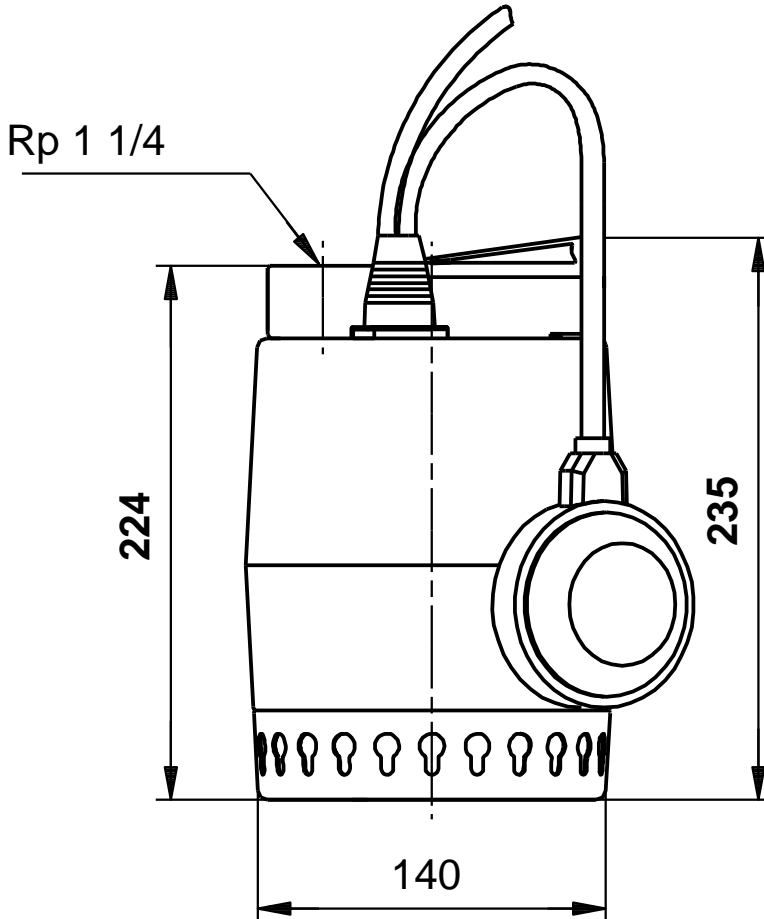

013N1600 Unilift KP 350 A 1 50

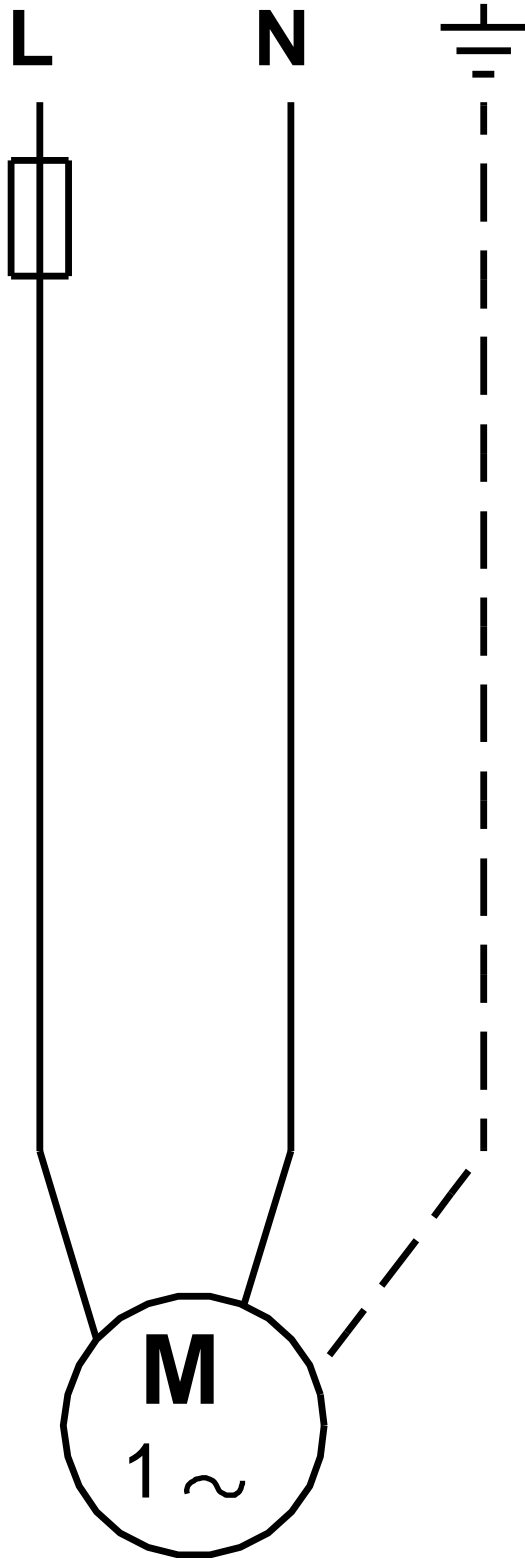

! [], .